

# STANDARD PRESSURE REGULATORS

DESCRIPTION	SUPPLY PRESSURE	PRESSURE RANGE	CONNECTION	SERIES	PAGE
	max. bar	bar	thread		
„Maxi“-Series, robust, interlockable	21	0.2 ... 1.8 / 17	G¼ - G1	R20, R21	<b>2.02</b>
made of plastic, also for liquids	12,5	0 ... 4 / 12	G½ - G1	R035 ... R095	<b>2.03</b>
extremely robust, high flow rate	21	0.2 ... 1.8 / 17	G¼ - G3	R119	<b>2.04</b>
Series „D“, made of aluminium	30	0.2 ... 1.5 / 15	G½ - G2	RD1 ... RD4	<b>2.06</b>
with joint supply	16	0.1 ... 3 / 16	G½ - G½	RB	<b>2.08</b>
lockable pressure regulator	16	0.1 ... 3 / 16	G½ and G1	RS	<b>2.09</b>
270° adjustment dial pressure regulator	21	0 ... 3 / 11	G¼ - G2	R11 ... R41	<b>2.10</b>



2

Standard



2

# "MAXI" PRESSURE REGULATOR

R20/R21

<b>Description</b>	Piston-type high-capacity regulator of modular design with exchangeable inserts. Can be interlocked with filter or lubricator without double nipples. Each "Maxi" regulator may be taken from a fixed line in seconds simply by removing the mounting bolts.	
<b>Media</b>	compressed air or non-corrosive gases	
<b>Supply pressure</b>	max. 21 bar	
<b>Adjustment</b>	R20: by plastic knob with snap-lock	R21: by T-handle with locknut
<b>Relieving function</b>	relieving, optionally non-relieving	
<b>Gauge port</b>	G $\frac{1}{4}$ on both sides of the body, screw plugs supplied	
<b>Mounting position</b>	any	
<b>Temperature range</b>	R20: 0 °C to 50 °C / 32 °F to 122 °F	R21: 0 °C to 80 °C / 32 °F to 176 °F
<b>Material</b>	Body: zinc die-cast Spring cage: zinc die-cast, adjusting knob made of glass fibre reinforced plastic	
<b>Elastomer:</b>	NBR/Buna-N	
<b>Inner valve:</b>	brass and plastic	

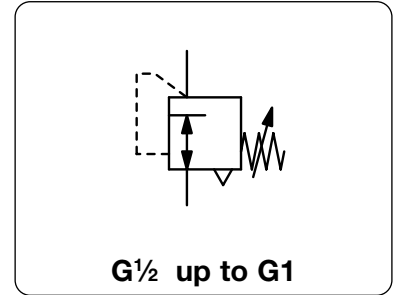

Standard

2

Dimensions			K <sub>v</sub> -value (m <sup>3</sup> /h)	Flow rate		Connection thread G	Pressure range bar	Order number
A	B	C		m <sup>3</sup> /h*1	l/min*1			

"Maxi" pressure regulator							supply pressure max. 21 bar, relieving, without pressure gauge	R20
89	162	38	5.2	372	6200	G $\frac{1}{2}$	0.2 ... 1.8 0.2 ... 4.0 0.3 ... 9.0 0.5 ... 17	R20-04A R20-04B R20-04C R20-04D
111	162	38	6.1	432	7200	G $\frac{3}{4}$	0.2 ... 1.8 0.2 ... 4.0 0.3 ... 9.0 0.5 ... 17	R20-06A R20-06B R20-06C R20-06D
111	162	38	6.3	450	7500	G1	0.2 ... 1.8 0.2 ... 4.0 0.3 ... 9.0 0.5 ... 17	R20-08A R20-08B R20-08C R20-08D



## Special options, add the appropriate letter

<b>T-handle</b>	including locknut	R21-0..
<b>NPT</b>	connection thread	R2.-0..N
<b>non-relieving</b>	without relieving function	R2.-0..K

## Accessories, enclosed

<b>pressure gauge</b>	Ø 63 mm, 0...*2 bar, G $\frac{1}{4}$	up to 16 bar	MA6302-...*2
<b>mounting bracket</b>	Ø 63 mm, 0...25 bar, G $\frac{1}{4}$	up to 25 bar	MA6302-...25
<b>mounting nut</b>	assembly at spring cage		BW45-02
<b>set of brackets</b>	made of plastic		M45x1,5K
	made of aluminium		M45x1,5A
	made of steel		MK20-0100

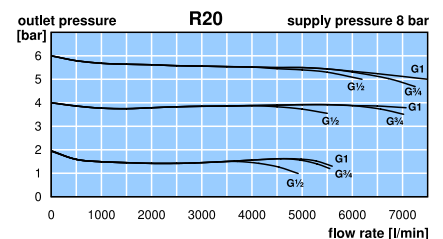
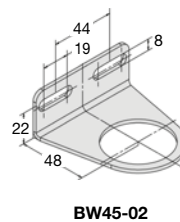
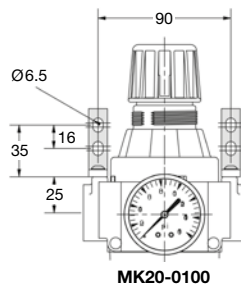
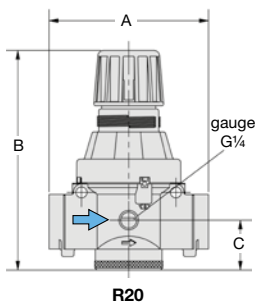

\*1 at 8 bar supply pressure, 6 bar outlet pressure and 1 bar pressure drop  
\*2 02 = 0...2.5 bar, 04 = 0...4 bar, 10 = 0...10 bar, 25 = 0...25 bar

\* Product group

Gauges: see chapter for measuring devices

PDF CAD  
www.aircom.net

Order example:  
R20-04A

# PLASTIC PRESSURE REGULATOR

## R035 ... R095

<b>Description</b>	Modular regulator, easy to interlock with other regulators, filters or filter regulators of the same series, without the need for double nipples or any other fittings. A sensitive rolling diaphragm allows good pressure regulation.		
<b>Media</b>	compressed air, non-corrosive gases or liquids		
<b>Supply pressure</b>	max. 12.5 bar, max. 10 bar for R035, max. 16 bar bei R042		
<b>Adjustment</b>	by plastic knob with snap-lock, R035 without snap-lock		
<b>Relieving function</b>	relieving, optionally non-relieving		
<b>Gauge port</b>	G $\frac{1}{8}$ on both sides of the body (G $\frac{1}{4}$ at R095), one screw plug supplied		
<b>Mounting position</b>	any		
<b>Temperature range</b>	0 °C to 50 °C / 32 °F to 177 °F		
<b>Material</b>	Body: nylon, Elastomer: NBR/Buna-N Inner valve: brass Thread insert: brass	POM at R035 and R042	

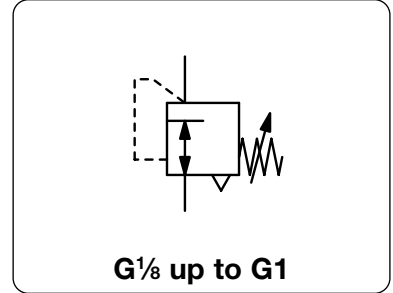

Standard  
2

Dimensions			K <sub>v</sub> -value (m <sup>3</sup> /h)	Flow rate		Connection thread G	Pressure range bar	Order number
A	B	C		m <sup>3</sup> /h*1	l/min*1			

Pressure regulator						supply pressure max. 12.5 bar, for series R035 max. 10 bar, for series R042 max. 16 bar, relieving, without pressure gauge		R0	
36	61	12	0.11	15	250	G $\frac{1}{8}$	0 ... 6	R035-01B	
							0 ... 6	R035-01RB	
42	102	20	0.36	51	850	G $\frac{1}{4}$	0 ... 4	R042-02B	
							0 ... 8	R042-02C	
							0 ... 12	R042-02D	
52	129	38	0.59	84	1400	G $\frac{3}{8}$	0 ... 4	R050-03B	
							0 ... 8	R050-03C	
							0 ... 12	R050-03D	
52	129	38	0.63	90	1500	G $\frac{1}{2}$	0 ... 4	R052-04B	
							0 ... 8	R052-04C	
							0 ... 12	R052-04D	
63	145	42	1.0	138	2300	G $\frac{1}{2}$	0 ... 4	R075-04B	
							0 ... 8	R075-04C	
							0 ... 12	R075-04D	
137	145	42	1.0	144	2400	G $\frac{3}{4}$	0 ... 4	R080-06B	
							0 ... 8	R080-06C	
							0 ... 12	R080-06D	
115	222	48	6.3	900	15000	G1	0 ... 4	R095-08B	
							0 ... 8	R095-08C	
							0 ... 12	R095-08D	



### Special options, add the appropriate letter

**non-relieving** without relieving function, also for liquids R0 .. -0 .. K

### Accessories, enclosed

<b>pressure gauge</b>	Ø 23 mm, 0... <sup>*2</sup> bar, G $\frac{1}{8}$ , max. 12 bar Ø 40 mm, 0... <sup>*2</sup> bar, G $\frac{1}{4}$ Ø 50 mm, 0... <sup>*2</sup> bar, G $\frac{1}{2}$ Ø 63 mm, 0... <sup>*2</sup> bar, G $\frac{3}{4}$	for R035 for R042 for R050 to R080 for R095	<b>MA2301-...<sup>*2</sup></b> <b>MA4001-...<sup>*2</sup></b> <b>MA5001-...<sup>*2</sup></b> <b>MA6302-...<sup>*2</sup></b>
<b>mounting bracket</b>	made of steel, mounting nut at the device	for R042 for R050 to R080	<b>BW30-01</b> <b>BW42-01</b>
<b>set of brackets</b>	made of steel	for R095	<b>BW00-02</b>
<b>connection clips</b>		for R035	<b>C350100018</b>

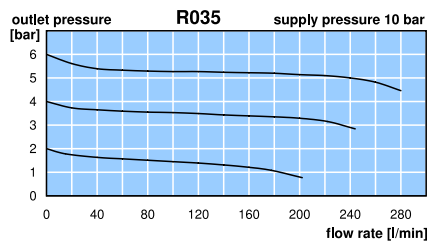
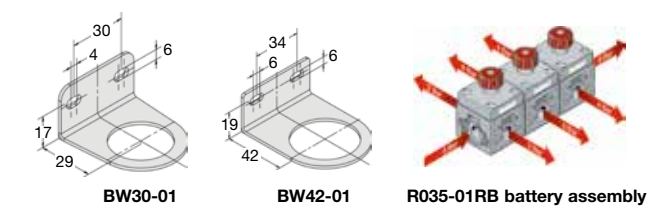
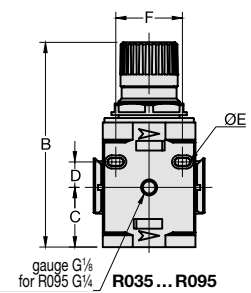

series	D	Ø E	F	K	L
R035	8	3.5	20	-	36
R042	10.5	4.5	31	-	42
R050/52	16	5.5	41	63	52
R075	17.5	5.5	45	75	63
R080	17.5	5.5	45	-	63
R095	65	8.5	174	115	95

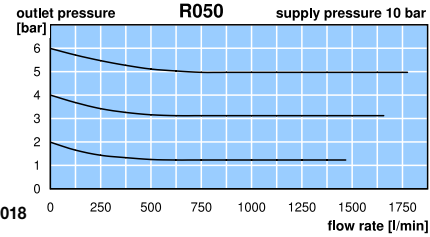

\*1 at 10 bar supply pressure, 6 bar outlet pressure and 1 bar pressure drop  
\*2 04 = 0...4 bar, 06 = 0...6 bar, 10 = 0...10 bar, 16 = 0...16 bar

\* Product group

# „STANDARD“ PRESSURE REGULATOR

R119

<b>Description</b>	High-capacity diaphragm regulator of solid design suitable for many applications. Ideal for installations where constant line pressure at wide flow variations. From size G2 on it is a pilot-operated piston regulator with an excellent regulation characteristic curve.	
<b>Media</b>	compressed air or non-corrosive gases	
<b>Supply pressure</b>	max. 21 bar, max. 16 bar by R119-16B/-20B/-24B	
<b>Air consumption</b>	from size G2 on the regulator's air consumption is about 0.1 l/min.	
<b>Adjustment</b>	by T-handle with locknut from size G2 on by plastic knob with snap-lock on the pilot regulator for G½ optionally by handwheel, for control panel integration	
<b>Relieving function</b>	relieving, optionally non-relieving	
<b>Gauge port</b>	G¼ on both sides of the body, screw plugs supplied	<b>Mounting position</b> any
<b>Temperature range</b>	0 °C to 50 °C / 32 °F to 122 °F, for appropriately conditioned compressed air down to -30 °C / -22 °F	
<b>Material</b>	Body: zinc die-cast Diaphragm: NBR/Buna-N	Inner valve: brass Bottom screw: reinforced nylon

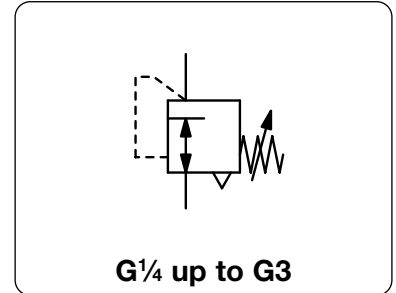

Dimensions			K <sub>v</sub> -value (m³/h)	Flow rate		Connection thread G	Pressure range bar	Order number
A	B	C		m³/h*1	l/min*1			
mm	mm	mm						

„Standard“ pressure regulator								supply pressure max. 21 bar, relieving, without pressure gauge	R119
70	157	35	1.5	150	2500	G¼	0.2 ... 1.8	R119-02A	
							0.2 ... 4.0	R119-02B	
							0.3 ... 9.0	R119-02C	
							0.5 ... 17	R119-02D	
83	172	38	3.6	360	6000	G¾*3	0.2 ... 1.8	R119-03A	
							0.2 ... 4.0	R119-03B	
							0.3 ... 9.0	R119-03C	
							0.5 ... 17	R119-03D	
83	172	38	3.6	360	6000	G½	0.2 ... 1.8	R119-04A	
							0.2 ... 4.0	R119-04B	
							0.3 ... 9.0	R119-04C	
							0.5 ... 17	R119-04D	
113	265	49	5.4	540	9000	G¾	0.3 ... 9.0	R119-06C	
							0.5 ... 17	R119-06D	
113	265	49	6.0	600	10000	G1	0.3 ... 9.0	R119-08C	
							0.5 ... 17	R119-08D	

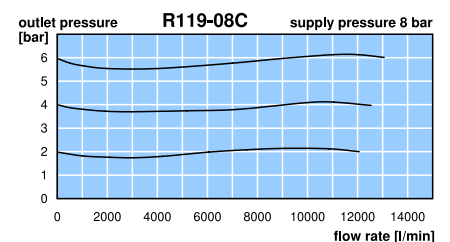
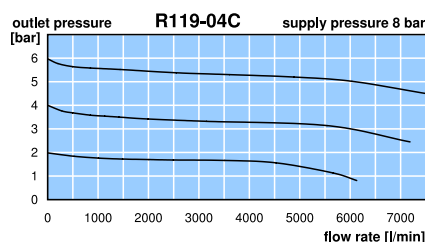
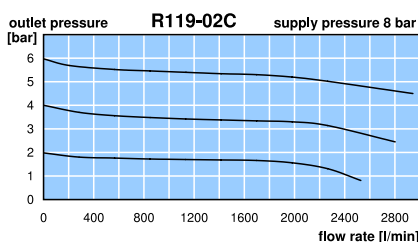
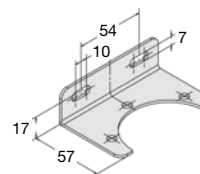
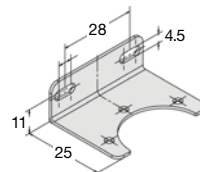
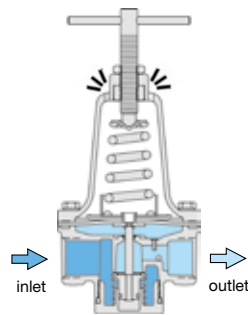
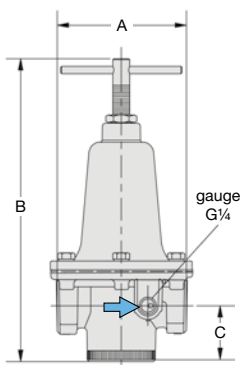

\*1 at 8 bar supply pressure, 6 bar outlet pressure and 1 bar pressure drop  
\*3 reduced by the next larger pressure regulator

\* Product group

PDF CAD  
www.aircom.net



Order example:  
R119-02A

<b>Description</b>	High-capacity diaphragm regulator of solid design suitable for many applications. Ideal for installations where constant line pressure at wide flow variations. From size G2 on it is a pilot-operated piston regulator with an excellent regulation characteristic curve.	
<b>Media</b>	compressed air or non-corrosive gases	
<b>Supply pressure</b>	max. 21 bar, max. 16 bar by R119-16B/-20B/-24B	
<b>Air consumption</b>	from size G2 on the regulator's air consumption is about 0.1 l/min.	
<b>Adjustment</b>	by T-handle with locknut from size G2 on by plastic knob with snap-lock on the pilot regulator for G½ optionally by handwheel, for control panel integration	
<b>Relieving function</b>	relieving, optionally non-relieving	
<b>Gauge port</b>	G¼ on both sides of the body, screw plugs supplied	<b>Mounting position</b> any
<b>Temperature range</b>	0 °C to 50 °C / 32 °F to 122 °F, for appropriately conditioned compressed air down to -30 °C / -22 °F	
<b>Material</b>	Body: zinc die-cast Diaphragm: NBR/Buna-N	Inner valve: brass Bottom screw: reinforced nylon

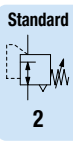
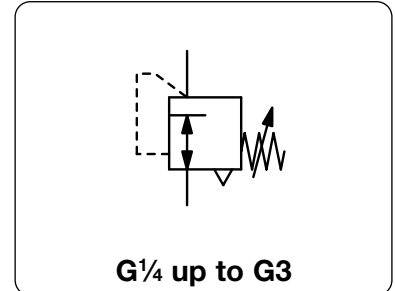

Dimensions			K <sub>v</sub> -value (m³/h)	Flow rate		Connection thread G	Pressure range bar	Order number
A	B	C		m³/h*1	l/min*1			
mm	mm	mm						

„Standard“ pressure regulator								supply pressure max. 21 bar, relieving, without pressure gauge	R119
126	275	48	6.6	660	11 000	G1¼*3	0.3... 9.0	R119-10C	
							0.5... 17	R119-10D	
126	275	48	7.2	720	12 000	G1½	0.3... 9.0	R119-12C	
							0.5... 17	R119-12D	
186	300	79	35.4	2520	42 000	G2	0.2... 7.0	R119-16B	
							0.8... 8.0	R119-16C	
							1.5... 15	R119-16D	
186	300	79	37.1	2640	44 000	G2½	0.2... 7.0	R119-20B	
							0.8... 8.0	R119-20C	
							1.5... 15	R119-20D	
214	360	95	56.0	6600	110 000	G3	0.2... 7.0	R119-24B	
							0.8... 8.0	R119-24C	
							1.5... 15	R119-24D	



Special options, add the appropriate letter				
<b>NPT</b>	connection thread	for G2 to G3	R119-...N	
<b>non-relieving</b>	without relieving function		R119-...K	
<b>FKM elastomer</b>		for G¼ to G1½	R119-...X64	
		for G3	R119-24.X64	
<b>panel mounting</b>	with handwheel, hole diameter 16 mm	for G½	R119-...P	
<b>flange connection</b>	see chapter SST devices / flanges		R119-...F.	
<b>PWIS-free</b>	for painting plants		R119-...LA	

Accessories, enclosed				
<b>pressure gauge</b>	Ø 50 mm, 0...*2 bar, G¼	for G¼ to G½	MA5002-...*2	
	Ø 63 mm, 0...*2 bar, G¼	for G¾ to G3	MA6302-...*2	
<b>mounting bracket</b>	made of steel	for G¼ and G¾	BW00-22	
		for G½	BW00-23	
		for G¾ to G1½	BW00-24	

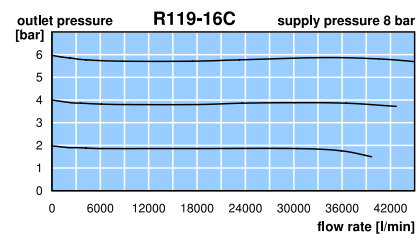
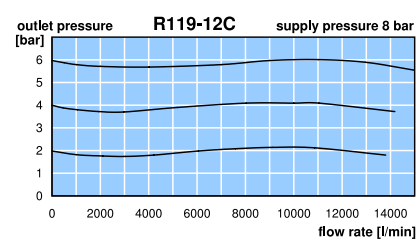
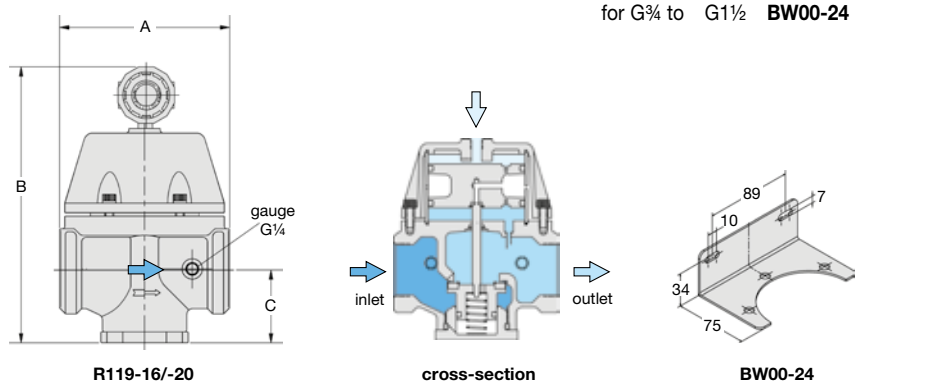

\*1 at 8 bar supply pressure, 6 bar outlet pressure and 1 bar pressure drop  
 \*2 02 = 0...2.5 bar, 04 = 0...4 bar, 06 = 0...6 bar, 10 = 0...10 bar, 16 = 0...16 bar  
 \*3 reduced by the next larger pressure regulator

**Description** Good value pressure regulator of solid design. RD1 and RD3 are equipped with diaphragms, RD4 is piston-operated. Wall mounting through two drilled holes in the bodies of RD1 to RD3.  
**Media** compressed air or non-corrosive gases  
**Supply pressure** max. 30 bar  
**Adjustment** RD1/RD2: see chart, by plastic knob with snap-lock  
 RD3: by handwheel  
 RD4: by T-handle  
**Relieving function** relieving, optionally non-relieving  
**Gauge port** G $\frac{1}{4}$  on both sides of the body, G $\frac{1}{2}$  at RD1  
**Mounting position** any  
**Temperature range** -10 °C to 50 °C / 14 °F to 122 °F, by RD1 and RD2  
 -20 °C to 60 °C / -4 °F to 140 °F, by RD3  
 -20 °C to 80 °C / -4 °F to 176 °F, by RD4  
**Material** Body: aluminium  
 Spring cage: plastic reinforced with glass fibre at RD1, nylon at RD2, aluminium at RD3/RD4  
 Elastomer: NBR/Buna-N Inner valve: brass at RD1/RD2, brass/aluminium at RD3/RD4

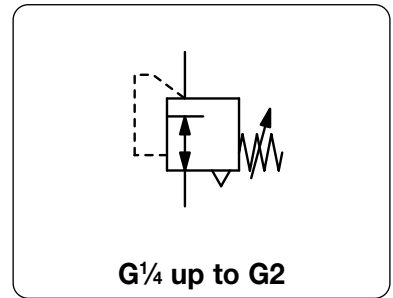

Standard  
2

Dimensions			K <sub>v</sub> -value	Flow rate	P <sub>1</sub> max.	Connection thread	Pressure range	Order number
A	B	C						

Pressure regulator							supply pressure max. 20 / 30 bar, relieving, without pressure gauge	RD1...RD4	
40	95	22	0.6	27	450	20	G $\frac{1}{8}$	0.2...1.5 0.3...3.0 0.5...8.0 1.5... 15	RD1-01A RD1-01B RD1-01D RD1-01E
40	95	22	0.6	27	450	20	G $\frac{1}{4}$	0.2...1.5 0.3...3.0 0.5...8.0 1.5... 15	RD1-02A RD1-02B RD1-02D RD1-02E
64	151	48	3.0	108	1800	20	G $\frac{3}{8}$	0.2...1.5 0.3...3.0 0.5...8.0 1.5... 15	RD2-03A RD2-03B RD2-03D RD2-03E
64	151	48	3.0	108	1800	20	G $\frac{1}{2}$	0.2...1.5 0.3...3.0 0.5...8.0 1.5... 15	RD2-04A RD2-04B RD2-04D RD2-04E
130	190	54	8.4	195	3250	30	G $\frac{3}{4}$	0.2...1.5 0.3...3.0 0.5...8.0 1.5... 15	RD3-06A RD3-06B RD3-06D RD3-06E
130	190	54	8.4	195	3250	30	G1	0.2...1.5 0.3...3.0 0.5...8.0 1.5... 15	RD3-08A RD3-08B RD3-08D RD3-08E
241	190	54	8.4	195	3250	30	G1 $\frac{1}{4}$	0.2...1.5 0.3...3.0 0.5...8.0 1.5... 15	RD3-10A RD3-10B RD3-10D RD3-10E
241	190	54	8.4	195	3250	30	G1 $\frac{1}{2}$	0.2...1.5 0.3...3.0 0.5...8.0 1.5... 15	RD3-1AA RD3-1AB RD3-1AD RD3-1AE



series	D	Ø E	M
RD1	30	4.5	M30x1,5
RD2	51	5.5	M50x1,5
RD3	76	6.5	-
RD4	76	8.5	-

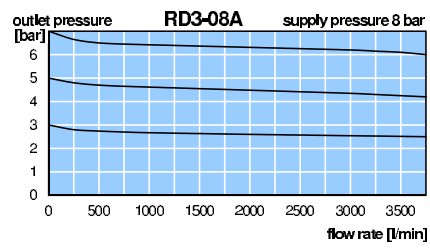
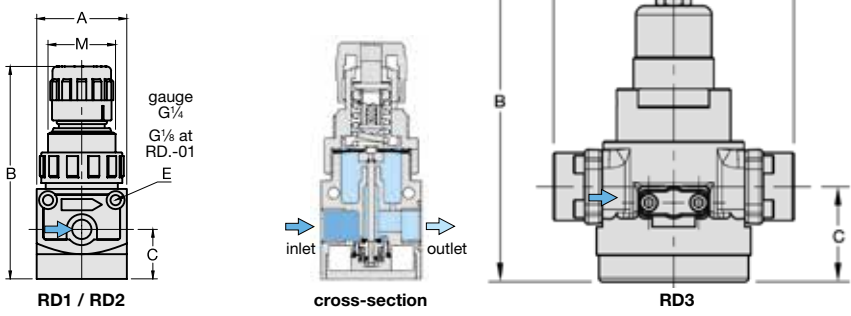

\*1 at 8 bar supply pressure, 6 bar outlet pressure and 1 bar pressure drop  
 \*2 02 = 0...2.5 bar, 04 = 0...4 bar, 10 = 0...10 bar, 16 = 0...16 bar

\* Product group

Gauges: see chapter for measuring devices

PDF CAD  
www.aircom.net

Order example:  
RD1-01A

# PRESSURE REGULATOR SERIES "D" UP TO 30 BAR

# RD1...RD4

<b>Description</b>	Good value pressure regulator of solid design. RD1 and RD3 are equipped with diaphragms, RD4 is piston-operated. Wall mounting through two drilled holes in the bodies of RD1 to RD3.
<b>Media</b>	compressed air or non-corrosive gases
<b>Supply pressure</b>	max. 30 bar
<b>Adjustment</b>	RD1/RD2: see chart, by plastic knob with snap-lock RD3: by handwheel RD4: by T-handle
<b>Relieving function</b>	relieving, optionally non-relieving
<b>Gauge port</b>	G $\frac{1}{4}$ on both sides of the body, G $\frac{1}{8}$ at RD1
<b>Mounting position</b>	any
<b>Temperature range</b>	-10 °C to 50 °C / 14 °F to 122 °F, by RD1 and RD2 -20 °C to 60 °C / -4 °F to 140 °F, by RD3 -20 °C to 80 °C / -4 °F to 176 °F, by RD4
<b>Material</b>	Body: aluminium Spring cage: plastic reinforced with glass fibre at RD1, nylon at RD2, aluminium at RD3/RD4 Elastomer: NBR/Buna-N Inner valve: brass at RD1/RD2, brass/aluminium at RD3/RD4

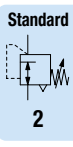
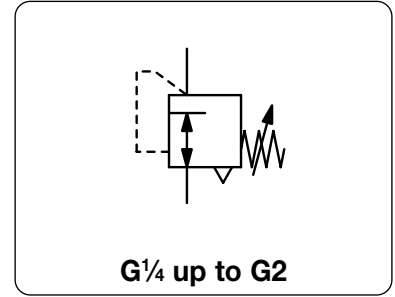

Dimensions			K <sub>v</sub> -value	Flow rate	P <sub>1</sub> max.	Connection thread	Pressure range	Order number
A	B	C						
mm	mm	mm	(m <sup>3</sup> /h)	m <sup>3</sup> /h*1	l/min*1	bar	G	bar

Pressure regulator								supply pressure 30 bar, relieving, without pressure gauge	RD1...RD4
174	386	122	25.0	1380	23 000	30	G $\frac{1}{2}$	0.2...1.5 0.3...3.0 0.5...8.0 1.5... 15	<b>RD4-12A</b> <b>RD4-12B</b> <b>RD4-12D</b> <b>RD4-12E</b>
174	386	122	25.0	1380	23 000	30	G2	0.2...1.5 0.3...3.0 0.5...8.0 1.5... 15	<b>RD4-16A</b> <b>RD4-16B</b> <b>RD4-16D</b> <b>RD4-16E</b>



**RD4**  
accessory: gauge

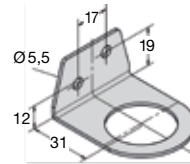

**BW30-02**

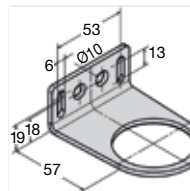

**BW50-03**

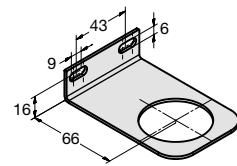

**BW45-03S**

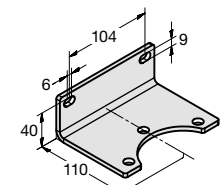

**BW00-68S**

## Special options, add the appropriate letter

non-relieving	without relieving function	RD . . . . K
30 bar operating pressure		RD . . . . H

## Accessories, enclosed

<b>pressure gauge</b>	Ø 40 mm, 0...*2 bar, G $\frac{1}{8}$	for RD1	<b>MA4001-..*2</b>
	Ø 50 mm, 0...*2 bar, G $\frac{1}{4}$	for RD2	<b>MA5002-..*2</b>
	Ø 63 mm, 0...*2 bar, G $\frac{1}{4}$	for RD3 and RD4	<b>MA6302-..*2</b>
<b>mounting bracket</b>	made of steel	for RD1	<b>BW30-02</b>
<b>mounting nut</b>	made of plastic	for RD1	<b>M30x1,5K</b>
<b>mounting bracket</b>	made of steel	for RD2	<b>BW50-03</b>
<b>mounting nut</b>	made of plastic	for RD2	<b>M50x1,5K</b>
<b>mounting bracket</b>	made of stainless steel	for RD3	<b>BW45-03S</b>
<b>mounting nut</b>	made of stainless steel	for RD3	<b>M45X-1,5S</b>
<b>mounting bracket</b>	made of stainless steel	for RD4	<b>BW00-68S</b>

series	D	Ø E	M
RD1	30	4.5	M30x1,5
RD2	51	5.5	M50x1,5
RD3	76	6.5	-
RD4	76	8.5	-

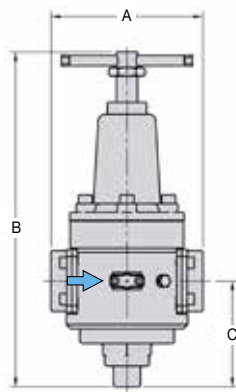

**RD4**

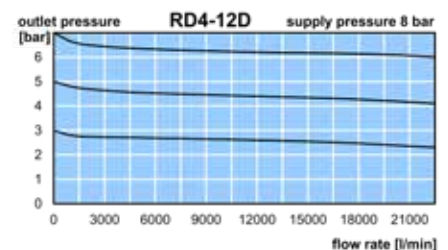

\*1 at 8 bar supply pressure, 6 bar outlet pressure and 1 bar pressure drop  
\*2 02 = 0...2.5 bar, 04 = 0...4 bar, 10 = 0...10 bar, 16 = 0...16 bar

\* Product group

Gauges: see chapter for measuring devices

PDF CAD  
www.aircom.net



Order example:  
**RD4-12A**

# PRESSURE REGULATOR FOR BATTERY WITH JOINT SUPPLY

RB

<b>Description</b>	Diaphragm pressure regulator, with joint pressure supply. Modular assembly without need for double nipples or other fittings. Outlet at rear side, gauge port in the front.		
<b>Media</b>	compressed air or non-corrosive gases		
<b>Supply pressure</b>	max. 16 bar		
<b>Air consumption</b>	without constant bleed		
<b>Adjustment</b>	by plastic knob with snap-lock		
<b>Relieving function</b>	relieving, optionally non-relieving		
<b>Gauge port</b>	G $\frac{1}{4}$		
<b>Mounting position</b>	any		
<b>Temperature range</b>	0 °C to 50 °C / 32 °F to 122 °F		
<b>Material</b>	Body: zinc die-cast, POM at R035	Adjusting knob: plastic	
	Elastomer: NBR/Buna-N	Inner valve: brass	

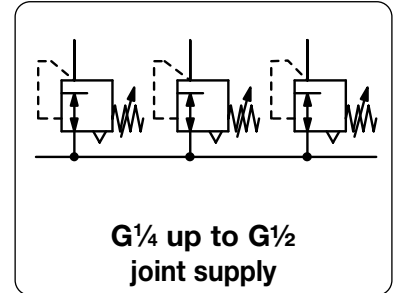

Standard  
2

Dimensions			K <sub>v</sub> - splitting value	Flow rate		Connection thread	Pressure range	Order number	Price B* €
A	B	C		m <sup>3</sup> /h	l/min*1				

Pressure regulator						supply pressure max. 16 bar, relieving		RB	
40	84	12	40	0.60	60	1000	G $\frac{1}{4}$	0.1 ... 3	RB-02B
								0.2 ... 6	RB-02C
								0.5 ... 10	RB-02D
48	94	22	45	1.3	126	2100	G $\frac{1}{4}$	0.1 ... 3	RB-A2B
								0.2 ... 6	RB-A2C
								0.5 ... 10	RB-A2D
								0.5 ... 16	RB-A2E
70	133	36	66	2.4	240	4000	G $\frac{1}{2}$	0.1 ... 3	RB-04B
								0.2 ... 6	RB-04C
								0.5 ... 10	RB-04D
								0.5 ... 16	RB-04E



battery block RB

## Accessories, enclosed

<b>pressure gauge</b>	Ø 23 mm, 0... <sup>*2</sup> bar, G $\frac{1}{8}$	for RB-02	<b>MA2301-..<sup>*2</sup></b>
	Ø 40 mm, 0... <sup>*2</sup> bar, G $\frac{1}{4}$ , connection parts required	for RB-A2	<b>MA4001-..<sup>*2</sup></b>
	Ø 50 mm, 0... <sup>*2</sup> bar, G $\frac{1}{4}$	for RB-03 / RB-04	<b>MA5001-..<sup>*2</sup></b>
<b>connection parts</b>	adapter for MA4001, G $\frac{1}{4}$ m to G $\frac{1}{2}$ f		<b>VI-0201</b>
<b>mounting bracket</b>	made of steel	for RB-02 / RB-A2	<b>BW30-02</b>
<b>mounting nut</b>	made of plastic	for RB-02 / RB-A2	<b>M30x1,5K</b>
<b>mounting bracket</b>	made of steel	for RB-04	<b>BW50-03</b>
<b>mounting nut</b>	made of plastic	for RB-04	<b>M50x1,5K</b>
<b>connector kit</b>		for RB-02	<b>KP00</b>
		for RB-A2	<b>KP11</b>
		for RB-04	<b>KP33</b>

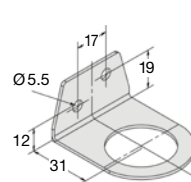
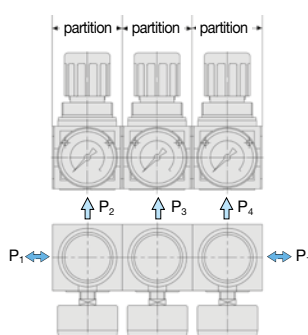
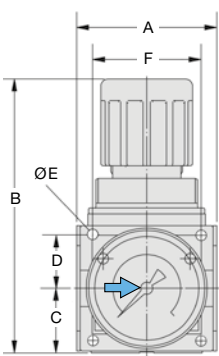

BW30-02

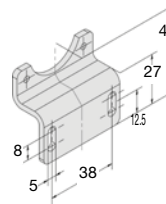

BW00-25

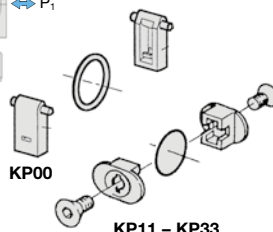

KP11 - KP33

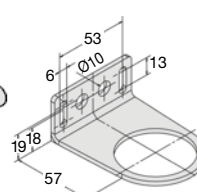

BW50-03

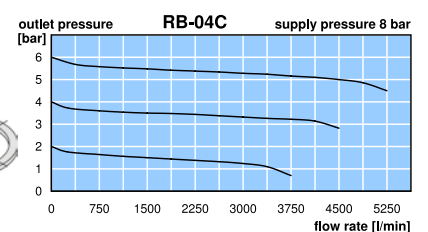
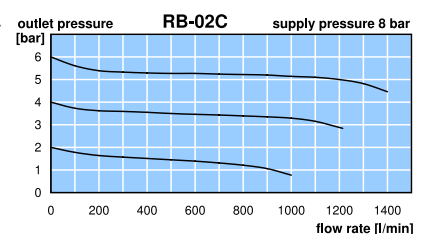

series	D	Ø E	F
R035	8	3.5	20
RB-A2	12	4.4	36
RB-04	18	5.5	54

\*1 at 8 bar supply pressure, 6 bar outlet pressure and 1 bar pressure drop  
\*2 04 = 0...4 bar, 06 = 0...6 bar, 10 = 0...10 bar, 16 = 0...16 bar

\* Product group

Gauges: see chapter for measuring devices

PDF CAD  
www.aircom.net



Order example:  
RB-02B



# LOCKABLE PRESSURE REGULATOR

RS

<b>Description</b>	Pressure regulator with diaphragm of solid design lockable with key		
<b>Media</b>	compressed air or non-corrosive gases		
<b>Supply pressure</b>	max. 16 bar		
<b>Air consumption</b>	no air consumption		
<b>Adjustment</b>	by handwheel, lockable		
<b>Relieving function</b>	relieving		
<b>Gauge port</b>	G $\frac{1}{8}$ on both sides of the body		
<b>Mounting position</b>	any		
<b>Temperature range</b>	-10°C to 60°C / 14°F to 140°F		
<b>Material</b>	Body: zinc die-cast	Diaphragm: NBR/Buna-N and brass	
	Lock cylinder: brass	Bottom screw: POM	
	Spring cage: POM and brass	O-ring: NBR/Buna-N	
	Adjusting spring: steel zinc-plated	Return spring: stainless steel	

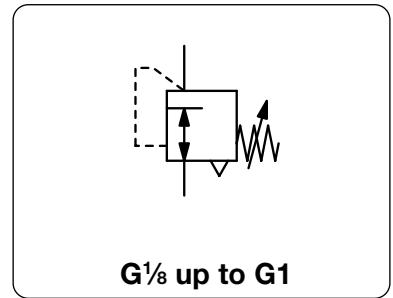

Standard  
2

Dimension			K <sub>v</sub> -value	Flow-rate	Connection thread	Pressure range	Order Number
A	B	C					
mm	mm	mm	m <sup>3</sup> /h	m <sup>3</sup> /h*1	l/min*1	G	bar

Lockable pressure regulator							supply pressure max. 16 bar, NBR elastomer for compressed air and neutral gases	RS
40	113	22	1,2	60	1000	G $\frac{1}{8}$	0,1 ... 3 0,2 ... 6 0,5 ... 10	RS-01A RS-01B RS-01C
48	123	27	1,4	90	1500	G $\frac{1}{4}$	0,1 ... 3 0,2 ... 6 0,5 ... 10 0,5 ... 16	RS-02A RS-02B RS-02C RS-02D
69	156	35	5,2	360	6000	G $\frac{1}{2}$	0,1 ... 3 0,2 ... 6 0,5 ... 10 0,5 ... 10	RS-04A RS-04B RS-04C RS-04D
100	209	52	6,1	600	10000	G1	0,1 ... 3 0,2 ... 6 0,5 ... 10 0,5 ... 10	RS-08A RS-08B RS-08C RS-08D



**Special options, add the appropriate letter**

up to -40°C      low temperature version      RS-0...X51

FKM elastomer      RS-0...V

Accessories, enclosed							
pressure gauge	Ø 40 mm, 0... <sup>*2</sup> bar	G $\frac{1}{8}$	for G $\frac{1}{8}$	MA4001-... <sup>*2</sup>			
	Ø 50 mm, 0... <sup>*2</sup> bar	G $\frac{1}{4}$	for G $\frac{1}{4}$ and G $\frac{1}{2}$	MA5002-... <sup>*2</sup>			
	Ø 63 mm, 0... <sup>*2</sup> bar	G $\frac{1}{4}$	for G1	MA6302-... <sup>*2</sup>			
mounting nut	made of plastic		for G $\frac{1}{8}$ and G $\frac{1}{4}$	M30x1,5K			
	made of aluminium		for G $\frac{1}{8}$ and G $\frac{1}{4}$	M30x1,5A			
	made of plastic		G $\frac{1}{2}$	M50x1,5K			
mounting bracket	made of steel		for G $\frac{1}{8}$ and G $\frac{1}{4}$	BW30-02			
			for G $\frac{1}{2}$	BW50-03			
			for G1	BW00-65			

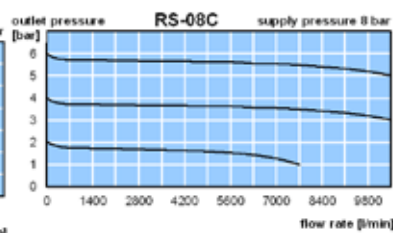
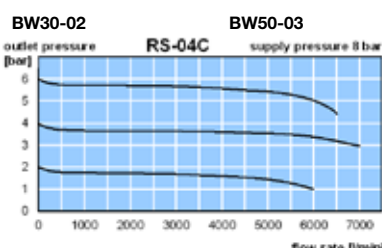
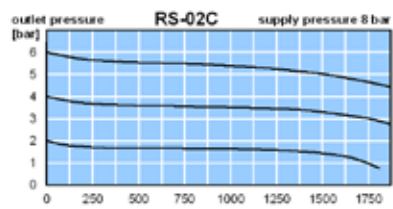
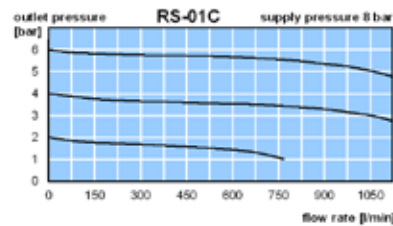
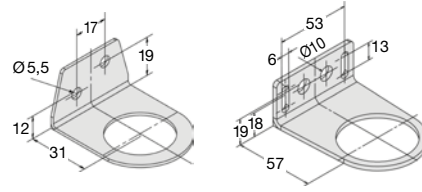
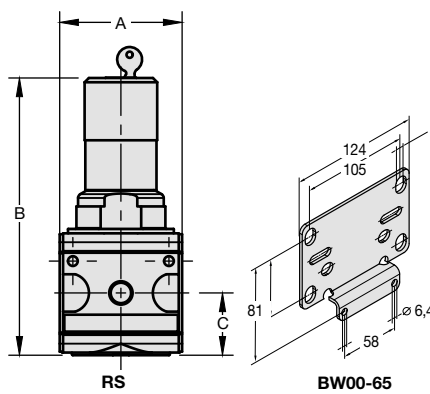

\*1 at 8 bar supply pressure, 6 bar outlet pressure and 1 bar pressure drop  
\*2 04 = 0...4 bar, 06 = 0...6 bar, 10 = 0...10 bar

# 270° ADJUSTMENT DIAL PRESSURE REGULATOR, LOCKABLE

R21...R41

**Description** Piston-operated regulator with balanced valve design and high-relief flow. Features include a transparent pressure-calibrated, non-rising adjusting dial which can be mounted in any position so the dial face is always visible. Pressure setting in steps is possible.

**Media** compressed air

**Supply pressure** max. 21 bar, minimum 1 bar above outlet pressure

**Air consumption** R21/R31/R41: max. 1.4 l/min depending on outlet pressure

**Adjustment** The full secondary pressure range can be dialed in less than a 270° turn proportional to handwheel with scale in bar or psi. This is advantageous if secondary pressure must be changed frequently.

**Relieving function** relieving

**Gauge port** G $\frac{1}{4}$  on both sides of the body

**Mounting position** any

**Temperature range** 0 °C to 65 °C / 32 °F to 149 °F

**Material** Body: zinc die-cast  
Piston: acetal  
Valve seat: acetal, brass and NBR/Buna-N  
O-ring: NBR/Buna-N

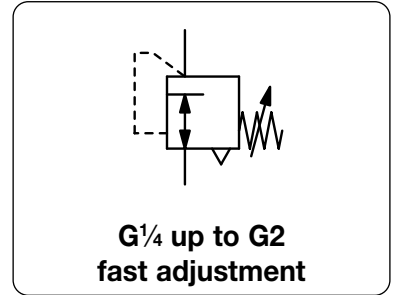

Dimensions			K <sub>v</sub> -value (m <sup>3</sup> /h)	Flow rate		Connection thread G	Pressure range bar	Order number
A	B	C		m <sup>3</sup> /h*1	l/min*1			

Adjustment dial regulator									supply pressure max. 21 bar, relieving, with constant bleed, adjusting dial 270° turn wheel	R21...R41
81	104	24	2.5	180	3000	G $\frac{1}{4}$	0... 3	R21-C2-L		
							0... 11	R21-C2-O		
81	104	24	3.8	270	4500	G $\frac{3}{8}$	0... 3	R21-C3-L		
							0... 11	R21-C3-O		
81	104	43	4.2	300	5000	G $\frac{1}{2}$	0... 3	R21-C4-L		
							0... 11	R21-C4-O		
109	132	43	6.8	480	8000	G $\frac{3}{4}$	0... 3	R31-C6-L		
							0... 11	R31-C6-O		
109	132	43	7.6	540	9000	G1	0... 3	R31-C8-L		
							0... 11	R31-C8-O		
135	173	71	18.5	1320	22000	G1 $\frac{1}{2}$	0... 3	R41-CB-L		
							0... 11	R41-CB-O		
135	173	71	20.0	1440	24000	G2	0... 3	R41-CC-L		
							0... 11	R41-CC-O		



## Special options, add the appropriate letter

adjustment lock RRP-95-585 R. 1-C . . T

## Accessories, enclosed

pressure gauge Ø 50 mm, 0...\*2 bar, G $\frac{1}{4}$  for R21 to R41 MA5002-..\*2  
mounting bracket mounting through the gauge port at the back for R21 to R41 RRP-95-590

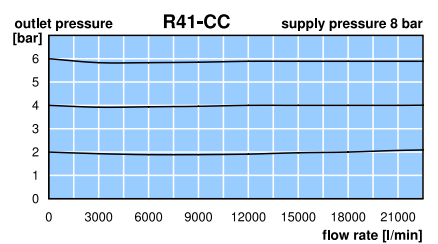
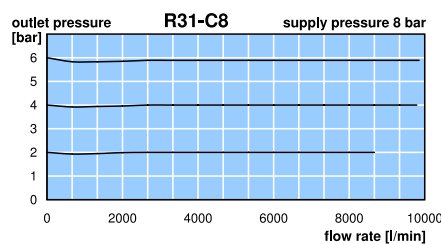
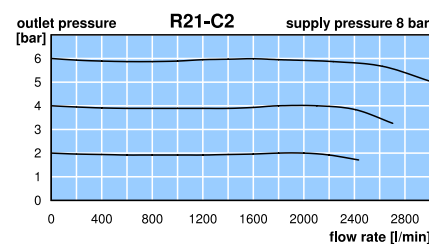
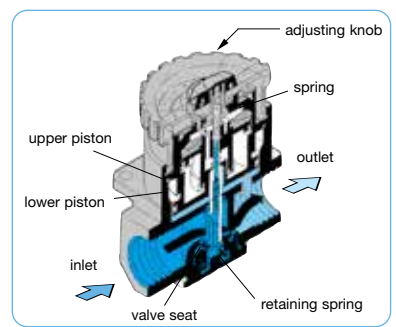
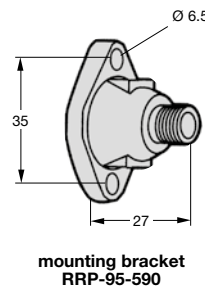
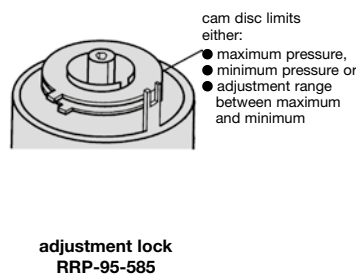
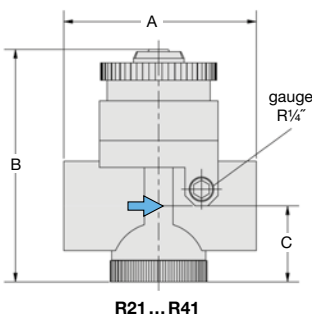

\*1 at 8 bar supply pressure, 6 bar outlet pressure and 1 bar pressure drop  
\*2 04 = 0...4 bar, 16 = 0...16 bar

\* Product group

Gauges: see chapter for measuring devices

PDF CAD  
www.aircom.net

Order example:  
R21-C2-L